



**HENRY PARK PRIMARY SCHOOL**  
**2025 PRELIMINARY EXAMINATION**  
**STANDARD SCIENCE**  
**PRIMARY SIX**  
**BOOKLET A**

Name: \_\_\_\_\_ (     )

Class: Primary 6 (     )

**28 QUESTIONS**

**56 MARKS**

**TOTAL TIME FOR BOOKLETS A & B: 1 HOUR 45 MINUTES**

**INSTRUCTIONS TO CANDIDATES**

1. Do not turn over this page until you are told to do so.
2. Follow all instructions carefully.
3. Answer all questions.

Marks for Booklet A: \_\_\_\_\_ / 56

Parent's Signature: \_\_\_\_\_

<b>Sections</b>	<b>Marks</b>
<b>A</b>	<b>/ 56</b>
<b>B</b>	<b>/ 44</b>



**Booklet A**

For each question from 1 to 28, four options are given. One of them is the correct answer. Make your choice (1, 2, 3 or 4). Shade the correct oval (1, 2, 3 or 4) on the **Optical Answer Sheet**.

(56 marks)

1 Study the diagram carefully.

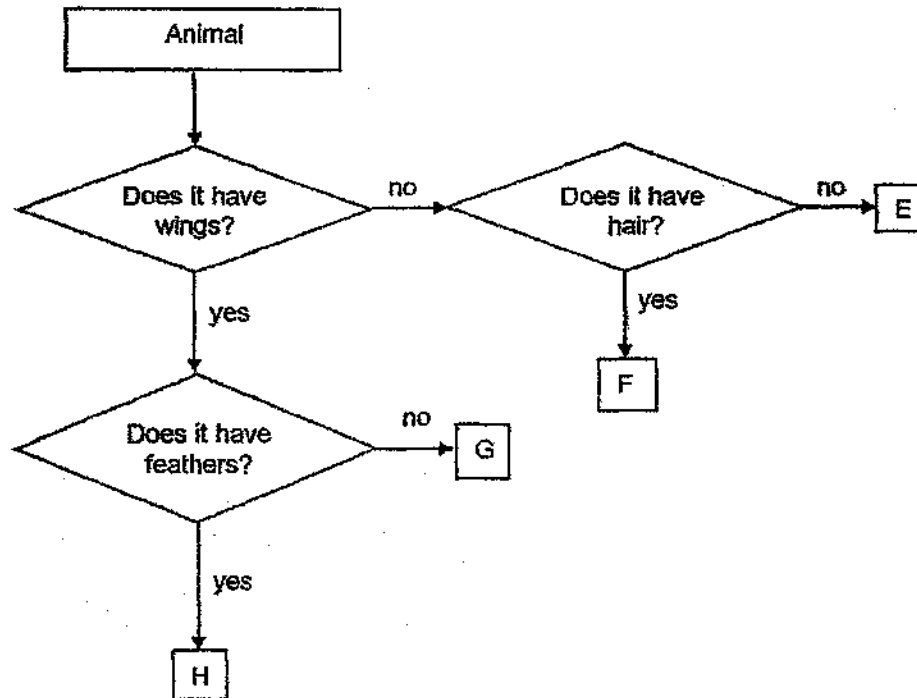

In which group should animal Q be placed?



Animal Q

- (1) E
- (2) F
- (3) G
- (4) H

2 The diagrams show organisms X and Y.

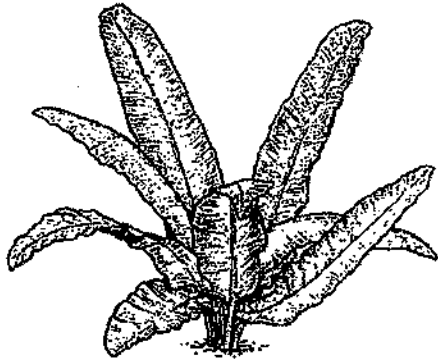

Organism X

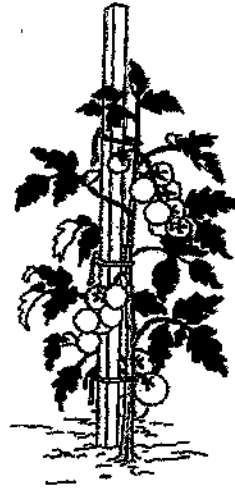

Organism Y

Which one of the following statements about organisms X and Y is correct?

- (1) Both produce flowers.
- (2) Both reproduce by spores.
- (3) Only organism Y can trap sunlight.
- (4) Both carry out photosynthesis.

- 3 The diagram shows how substances V and W are transported in the human body.

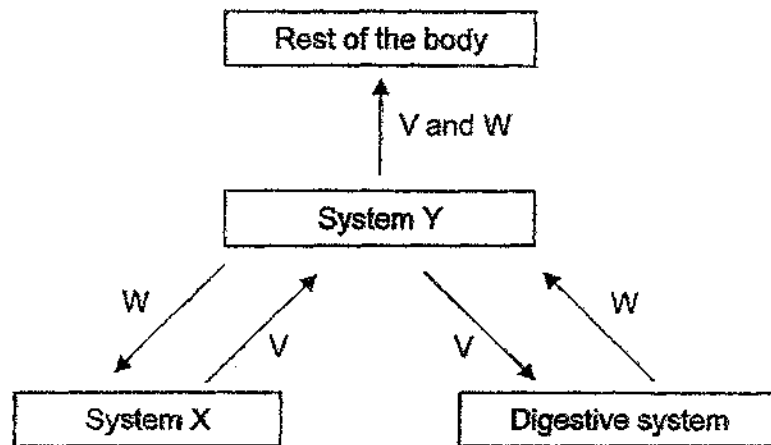

Which one of the following correctly identifies substances V and W and systems X and Y?

	Substance		System	
	V	W	X	Y
(1)	digested food	oxygen	circulatory	respiratory
(2)	digested food	oxygen	respiratory	circulatory
(3)	oxygen	digested food	circulatory	respiratory
(4)	oxygen	digested food	respiratory	circulatory

- 4 The diagrams show the life cycles of the mosquito and the grasshopper.

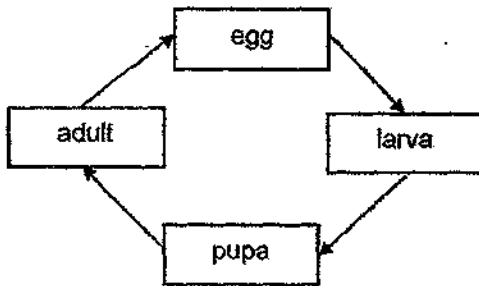

Mosquito

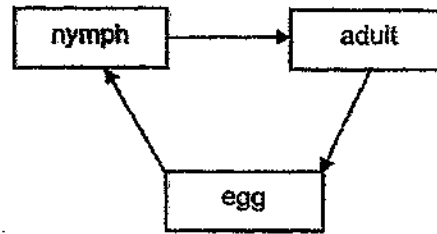

Grasshopper

Based on the diagrams, which of the following are correct for both animals?

- A adult has wings
- B young resembles the adult
- C young lives in the water
- D adult reproduces by laying eggs

- (1) A and C only
  - (2) A and D only
  - (3) B and C only
  - (4) B and D only
- 5 The diagram shows a food web observed in an ocean habitat.

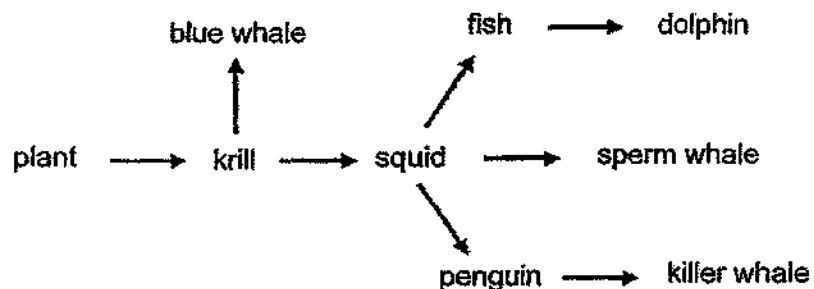

Which of the following is likely to cause an increase in the population of squids?

- A A decrease in the population of killer whales
- B A decrease in the population of blue whales
- C A decrease in the population of sperm whales

- (1) A and B only
  - (2) B and C only
  - (3) A and C only
  - (4) A, B
- For more papers, Go to: [SeriousAboutSchool.com/OnlineExams](http://SeriousAboutSchool.com/OnlineExams)

6 Annie conducted an experiment with flower P.

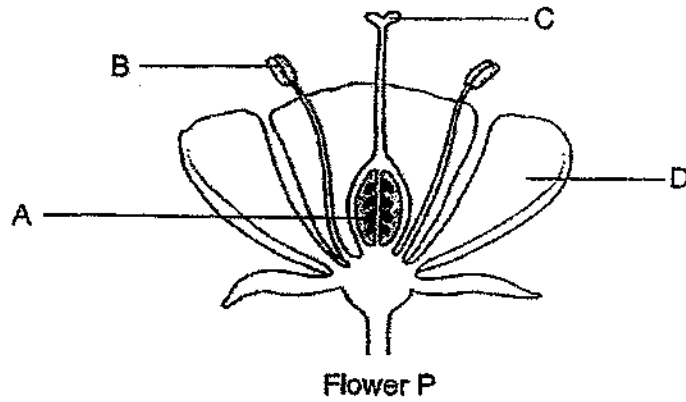

She removed two parts of flower P. She then transferred some pollen from another flower of the same plant to the remaining parts of flower P.

After some time, a fruit was formed.

Which two parts of flower P had been removed?

- (1) A and C
- (2) A and D
- (3) B and C
- (4) B and D

- 7 A plant with leaves of green and white areas was left in a dark cupboard for two days. Diagram 1 shows one of its leaves.

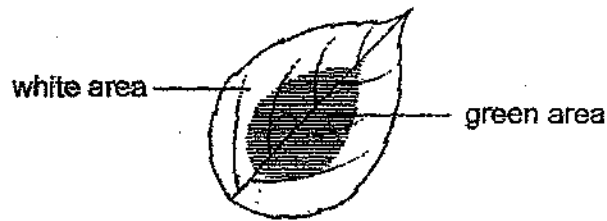

Diagram 1

The top and bottom of a leaf was partially covered with black papers as shown in diagram 2.



Diagram 2

The plant was then left in the sun. After one day, the leaf was removed and tested for starch.

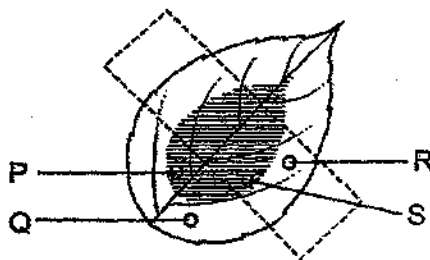

In which area(s) is starch mostly found?

- (1) Q only
- (2) P only
- (3) Q and P only
- (4) R and S only



8 The table shows grouping of cells P, Q, R and S.

	Has chloroplasts	Has no chloroplasts
Has cell wall	P	R
Has no cell wall	Q	S

Based on the table above, which of the following is likely to be correct?

- (1) P is a leaf cell.
- (2) S is a plant cell.
- (3) P and Q are from a plant.
- (4) R and S are from an animal.

9 The diagram shows the human digestive system.

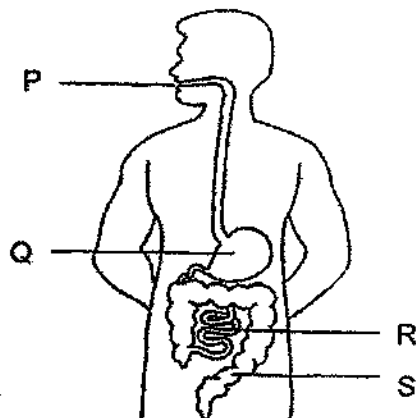

Which of the following statement(s) is/are correct?

- A Digestion ends at R.
- B S has the most digested food.
- C There is more undigested food at P than Q.
- D Digestive juices are produced at Q and R only.

- (1) B only
- (2) A and C only
- (3) B and C only
- (4) A.

10 Insect F looks like a bee, but it does not have a poisonous sting like a bee does.

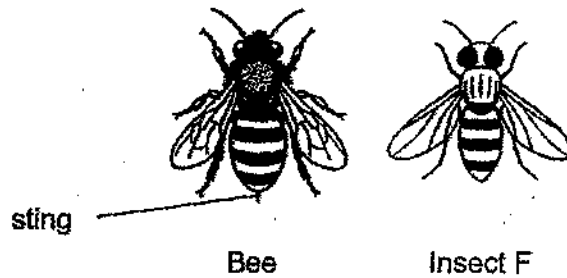

Which one of the following statements about insect F's adaptation is correct?

- (1) Insect F can grow a sting to protect itself.
- (2) Insect F can reproduce with bees to have more offsprings.
- (3) Predators of insect F will mistake them for bees and not go near them.
- (4) Predators of insect F have more prey to feed on as they can also feed on bees.

11 A plant was cut at points X and Y as shown in the diagram below.  
At point X, both the food-carrying tubes and water-carrying tubes were removed.  
At point Y, only the food-carrying tubes were removed.

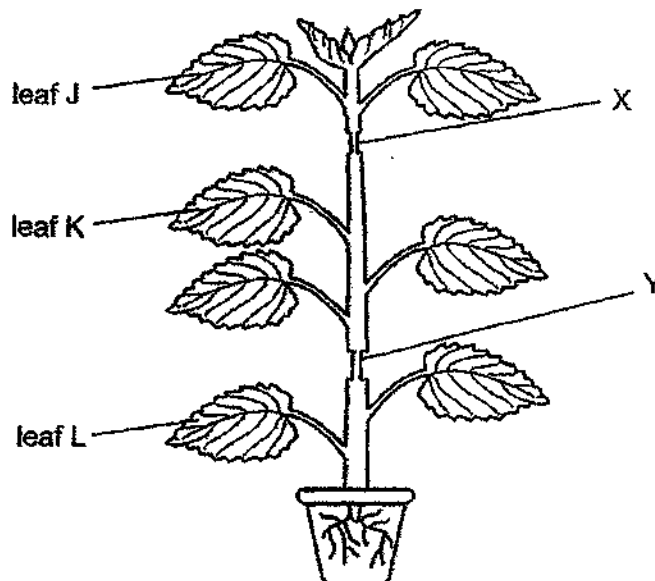

Which of the following statements about leaves J, K and L is correct?

- (1) Only leaf L would be able to photosynthesise.
- (2) Only leaf K would be able to photosynthesise.
- (3) Both leaves K and L would be able to photosynthesise.
- (4) Lea For more papers, Go to: [SeriousAboutSchool.com/OnlineExams](http://SeriousAboutSchool.com/OnlineExams)

12 The diagram below shows a food web.

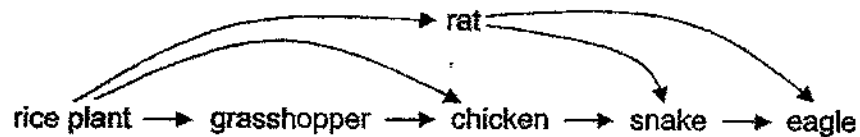

After animal X was released into the field, the number of grasshoppers increased, and the number of rats decreased.

Which organism did animal X feed on?

- (1) snake
- (2) chicken
- (3) rice plant
- (4) grasshopper

13 The diagram shows the experimental set-up Joe used to investigate the effect of a plant on the amount of carbon dioxide in the surrounding air.

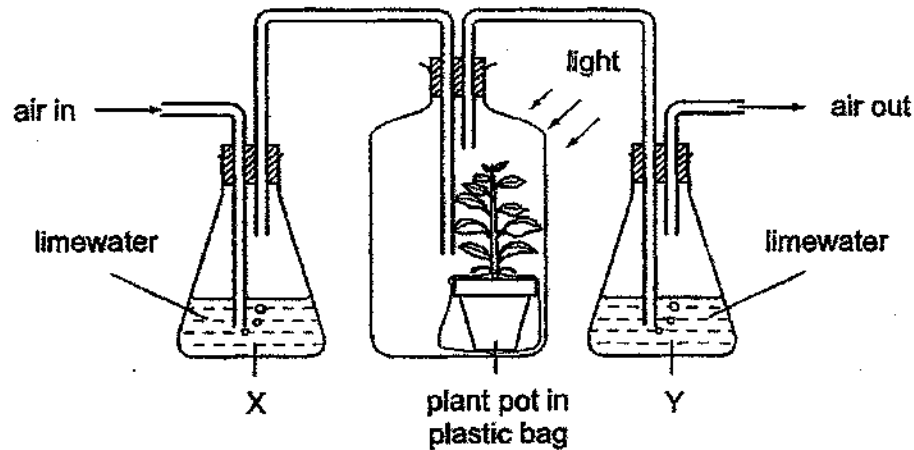

Limewater becomes cloudy when it mixes with carbon dioxide.

What happens to the limewater in flask X and in flask Y in the above set-up?

	Limewater in X	Limewater in Y
(1)	becomes cloudy	becomes cloudy
(2)	becomes cloudy	remains clear
(3)	remains clear	becomes cloudy
(4)	remains clear	remains clear

14 Susan conducted an experiment with 4 types of soil, P, Q, R and S.

She poured  $100 \text{ cm}^3$  of water into soil P and measured the amount of water collected in the glass container after 10 minutes as shown in the diagram below.

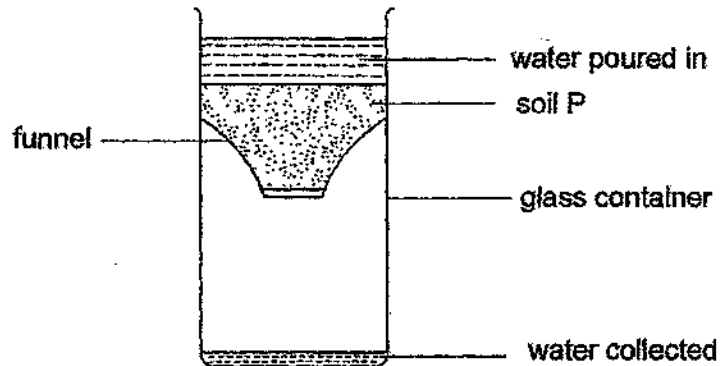

She repeated the experiment for soil Q, R and S.

The table below shows her results.

Type of soil	P	Q	R	S
Amount of water collected ( $\text{cm}^3$ )	97	50	10	70

The picture below shows plant X which has shallow roots that cannot grow deep into the ground.

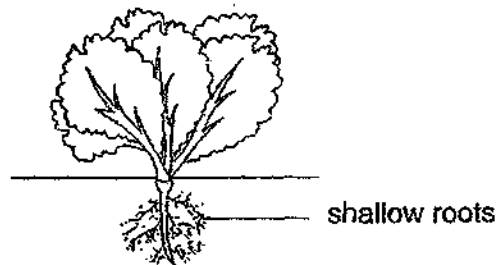

Which soil is plant X most adapted to grow in?

- (1) P
- (2) Q
- (3) R
- (4) S

- 15 Water quality in rivers can be measured by studying the types of aquatic animals that live in the river.

As the level of pollutants increases in a river, some animals are not able to survive as well as other animals.

The diagram shows some aquatic animals' tolerance level to pollutants in a river.

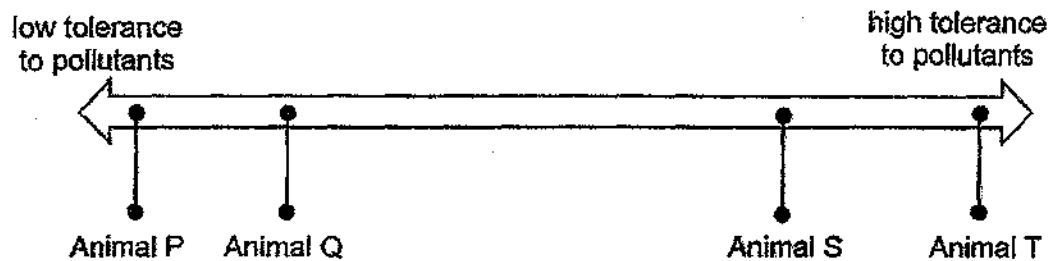

Water samples were taken from four different rivers and the number of animals P, Q, S and T were counted and recorded in the table below.

River	Number of aquatic animals observed in the water samples			
	P	Q	S	T
W	6	10	10	8
X	10	12	4	4
Y	0	4	8	12
Z	0	0	10	16

Based on the information given, which of the following correctly identifies the level of pollution in the four rivers?

	least polluted			most polluted
(1)	Y	Z	W	X
(2)	X	W	Y	Z
(3)	W	Y	X	Z
(4)	Z	Y	W	X

16 As the water in the kettle is boiling, white mist is observed near the spout as shown below.



Which of the following correctly describes the white mist?

	Process by which the white mist is formed	Property of the white mist
(1)	Boiling	It does not have a definite shape.
(2)	Boiling	It does not have a definite volume.
(3)	Condensation	It does not have a definite shape.
(4)	Condensation	It does not have a definite volume.

17 The diagram below shows a hanging plant.

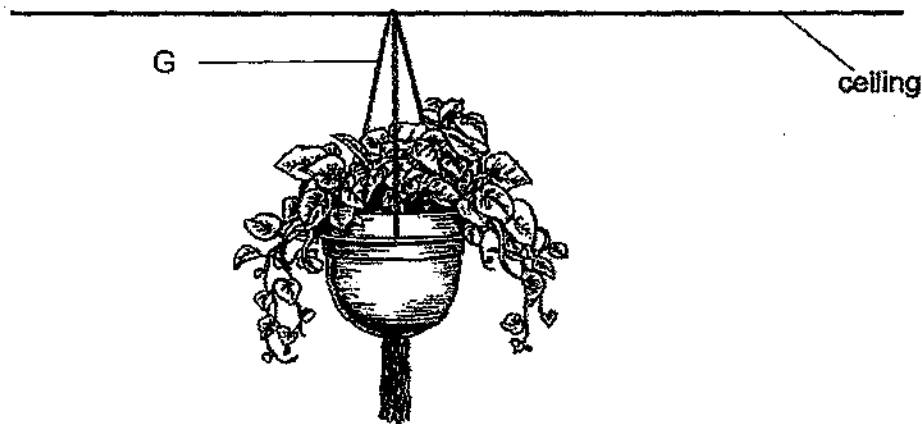

The plant can be hung from a ceiling because of part G.

Which one of the properties of part G enable the plant to be hung as shown in the diagram above?

- (1) flexible
- (2) strength
- (3) can float
- (4) wal

For more papers, Go to: [SeriousAboutSchool.com/OnlineExams](http://SeriousAboutSchool.com/OnlineExams)

- 18 Cally placed a balloon filled with air in a container of water. The balloon was floating on the water.

Cally then pushed the balloon downwards and he observed that water in the container overflowed as shown in Figure 2.

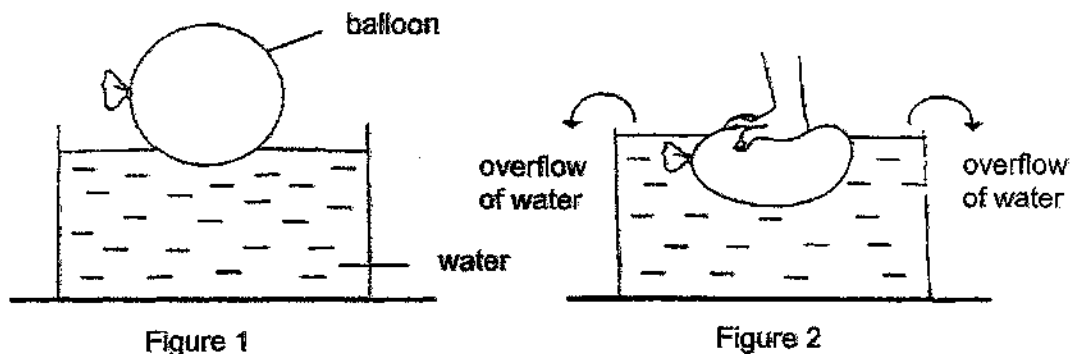

Based on Cally's observation, which of the following describes the air in the balloon?

- A The air in the balloon has mass.
  - B The air in the balloon occupies space.
  - C The air in the balloon has fixed shape.
  - D The air in the balloon can be compressed.
- (1) A and B only  
(2) B and D only  
(3) A and C only  
(4) B, C and D only

19 The diagram below shows the changes of state in water.

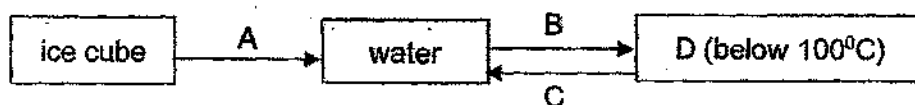

Based on the diagram given, which of the following is correct?

	Process A	Process B	Process C	Substance D
(1)	lose heat	gain heat	lose heat	steam
(2)	gain heat	lose heat	gain heat	water vapour
(3)	lose heat	gain heat	gain heat	steam
(4)	gain heat	gain heat	lose heat	water vapour

20 Substance W is a liquid at 25°C. It becomes a gas when it reaches 60°C.

Based on the information given, which of the following is correct?

	Statement	True	False	Not possible to tell
A	Substance W is a liquid at 55°C.		✓	
B	Substance W is a liquid at 35°C.		✓	
C	Substance W is a solid at 5°C.			✓
D	Substance W is a liquid at 80°C.	✓		

- (1) A
- (2) B
- (3) C
- (4) D



21 Hula investigated why metals feel cool when touched.

She pasted a thermometer strip to measure the changes in the temperature of two similar trays made of different materials for one minute.

She placed her hand on the surface of the two trays for 10 seconds each and took the temperature readings.

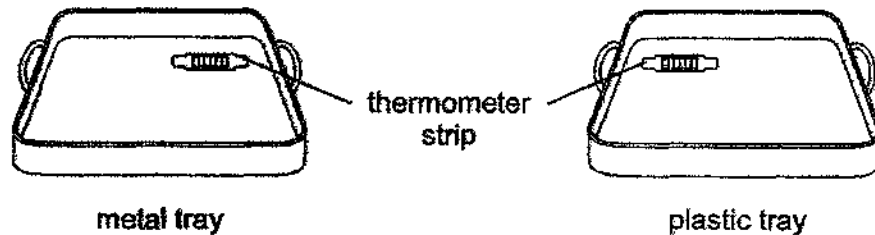

Which one of the following data tables represent the temperature readings correctly?

(1)

		<i>hand on tray</i>				
<b>tray \ sec</b>	<b>0</b>	<b>5</b>	<b>10</b>	<b>15</b>	<b>20</b>	
metal	26	26	29	31	28	
plastic	26	26	27	28	27	

(2)

		<i>hand on tray</i>				
<b>tray \ sec</b>	<b>0</b>	<b>5</b>	<b>10</b>	<b>15</b>	<b>20</b>	
metal	26	25	27	28	27	
plastic	26	25	29	31	28	

(3)

		<i>hand on tray</i>				
<b>tray \ sec</b>	<b>0</b>	<b>5</b>	<b>10</b>	<b>15</b>	<b>20</b>	
metal	25	25	28	30	32	
plastic	26	26	27	28	29	

(4)

		<i>hand on tray</i>				
<b>tray \ sec</b>	<b>0</b>	<b>5</b>	<b>10</b>	<b>15</b>	<b>20</b>	
metal	25	25	25	25	25	
plastic	28	28	28	28	28	

- 22 Betty wanted to draw the images of animals.  
She used her toys to draw their shadows on a paper instead, as shown below.

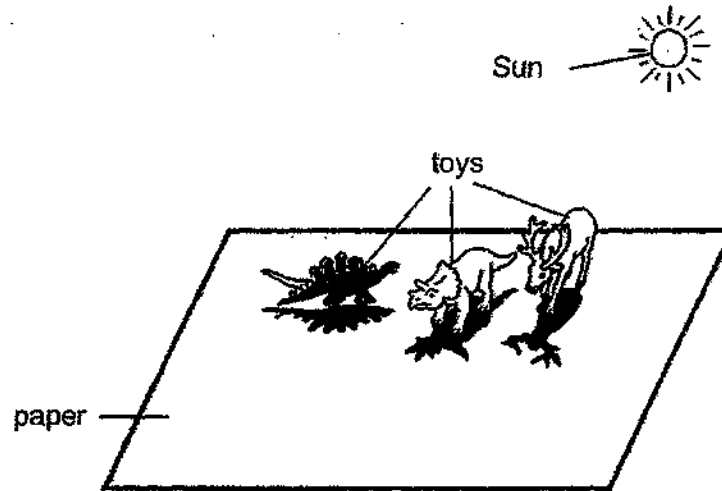

To create shadows of animals of different sizes, which of the following should she do?

- A Trace the animal toys' shadows at different times of the day.
  - B Place the animal toys at different parts of the paper.
  - C Draw the shadow of the animal toy when it is cloudy.
- (1) A and B only  
(2) B and C only  
(3) A and C only  
(4) A, B and C

23 A ball is held at rest on one side of a curved track.

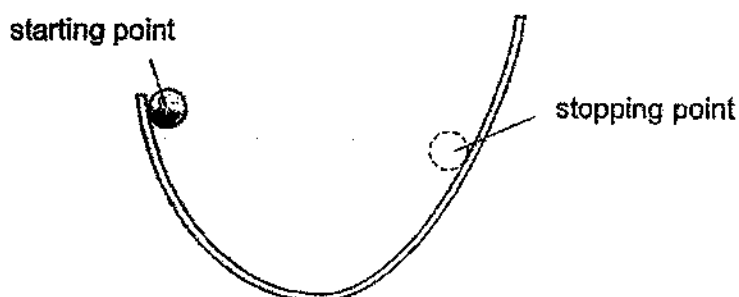

The ball is released. It rolls down one side of the track and part of the way up the other side. It then stops, before rolling back down again. The height of the stopping point is less than that of the starting point.

What is the correct order of energy conversion between the starting and stopping points?

- (1) potential energy → kinetic energy → potential energy
- (2) potential energy → kinetic energy → heat → potential energy
- (3) kinetic energy → potential energy + heat → kinetic energy + heat
- (4) potential energy → kinetic energy + heat → potential energy + heat

24 The diagram below shows how energy is supplied to run a hair dryer.

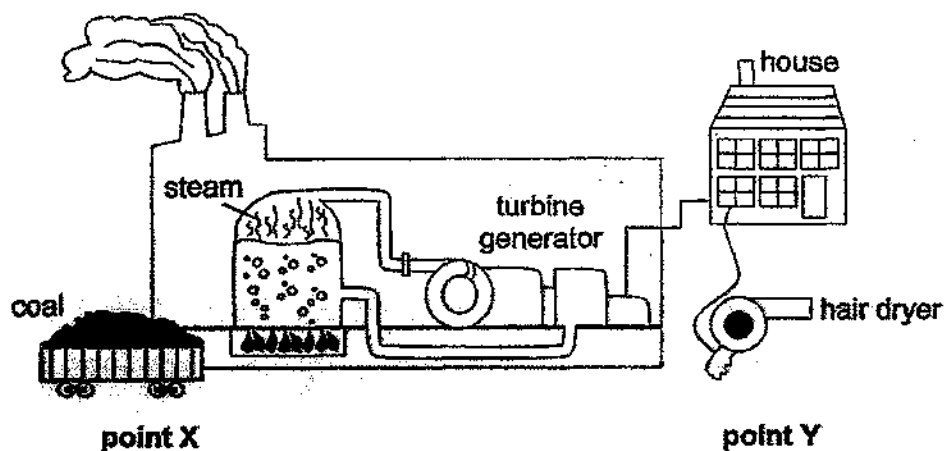

As the energy moves from point X to point Y in the diagram, the energy stored in the coal \_\_\_\_\_.

- (1) is used up
- (2) is converted to electrical energy
- (3) reduces the friction in the turbine generator
- (4) increases the sound energy in the hair dryer

- 25 The circuit below, consists of four similar batteries, four similar bulbs and four similar bars, W, X, Y, Z, which are made of different materials.

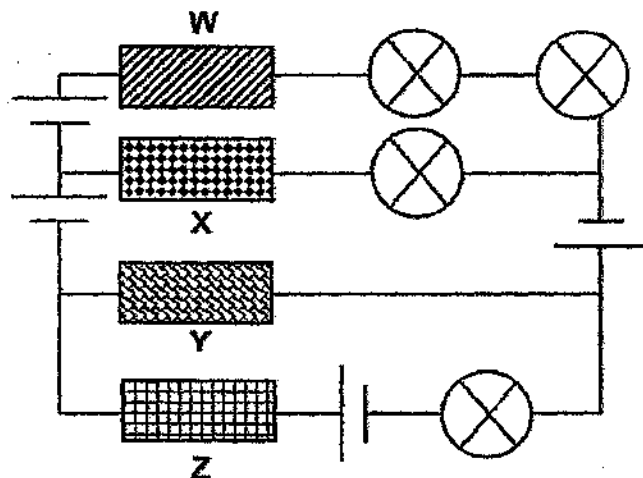

Which one of the following classifications of the 4 materials is correct if only one bulb in the circuit is lit?

(1)

Conductors of electricity	Non-conductors of electricity
X	W
Z	Y

(2)

Conductors of electricity	Non-conductors of electricity
X	W
Y	
Z	

(3)

Conductors of electricity	Non-conductors of electricity
Y	W
Z	X

(4)

Conductors of electricity	Non-conductors of electricity
W	X
Z	Y

- 26 The diagram shows four circuits with different arrangements of identical batteries and identical bulbs.

The bulbs in all four circuits light up.

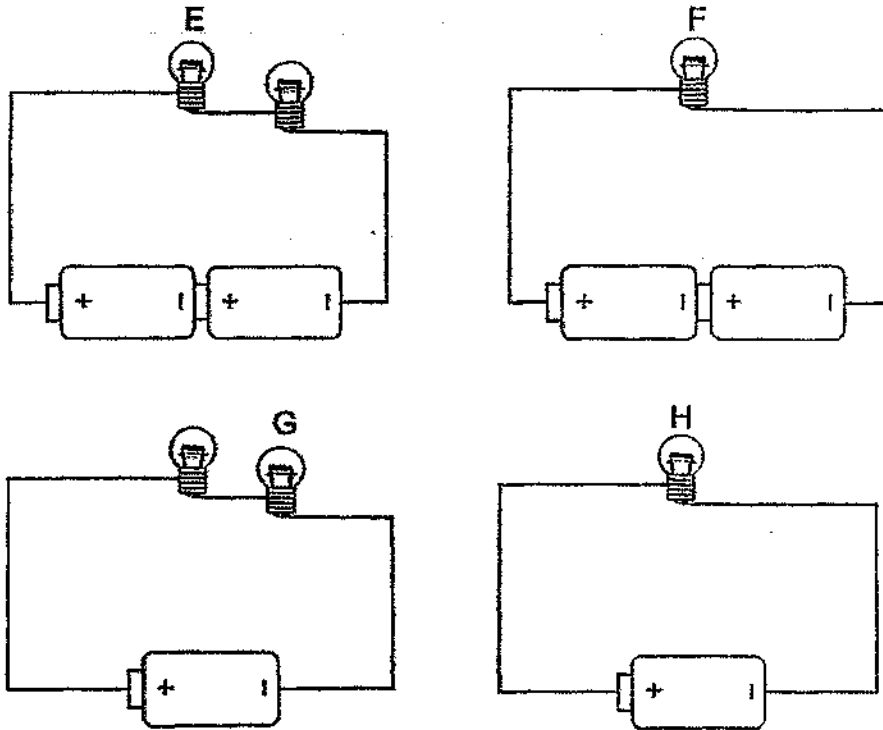

Based on the information given, which one of the following shows the brightness of the bulbs E, F, G and H?

Brightness of bulbs		
Low	Medium	High
(1) G	H	E
(2) G	E	F
(3) E	F	G
(4) E	H	F

- 27 Daffy made a magnet holder to investigate how the number of tapes attached to a magnet could affect the number of paper clips it could attract as shown in diagram 1. Diagram 2 shows the paper clips attracted to the magnet.

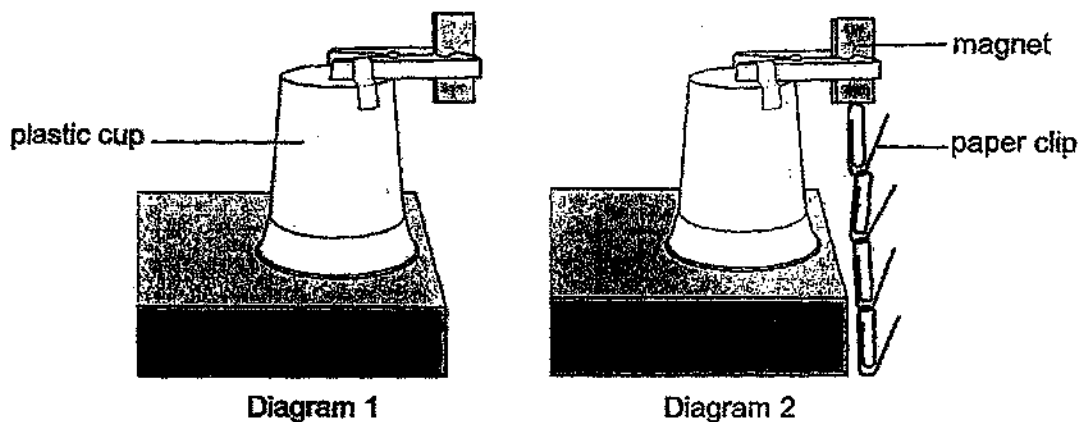

She then added different numbers of tape to one end of the magnet and repeated the investigation for each of these different numbers of tape, as shown below.

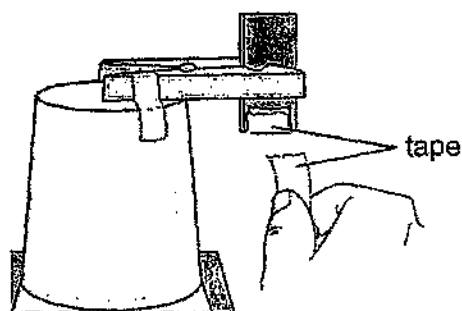

The data collected for the investigation is shown below.

Magnet with different number of tapes added					
	Magnet with no tape	Magnet with 1 piece of tape	Magnet with 3 pieces of tape	Magnet with 5 pieces of tape	Magnet with 7 pieces of tape
Number of paper clips attracted by magnet	19	11	7	5	3

Based on the data collected, what is Daffy investigating?

- (1) How is the strength of the magnet affected by magnetic materials around it?
- (2) How does the amount of non-magnetic material added, determine the size of a magnet?
- (3) How does the force of gravity affect the amount of the magnetic force exerted on the paper clips?
- (4) How is the strength of a magnet affected by the distance between the paper clips and the magnet?

- 20 In winter, some countries require drivers to fix snow chains to their car tyres when driving through snow and ice. The diagram below shows how the snow chain is attached to the tyre.

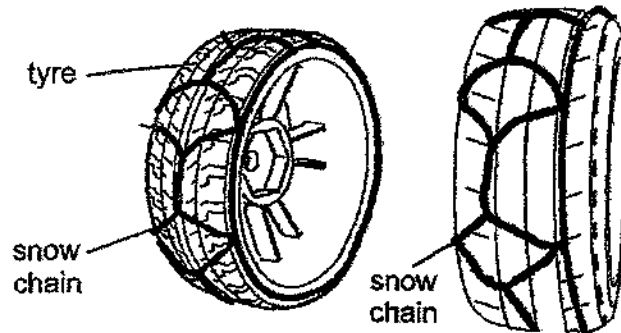

What is the purpose of the snow chain?

- (1) To increase the mass of the car.
- (2) To increase friction on the slippery road.
- (3) To help the cars move in a straight path.
- (4) To increase the potential energy of the car.

**End of Booklet A**



**HENRY PARK PRIMARY SCHOOL**  
**2025 PRELIMINARY EXAMINATION**  
**STANDARD SCIENCE**  
**PRIMARY SIX**  
**BOOKLET B**

Name: \_\_\_\_\_ ( )

Class: Primary 6 ( )

**12 QUESTIONS**

**44 MARKS**

**TOTAL TIME FOR BOOKLETS A & B: 1 HOUR 45 MINUTES**

**INSTRUCTIONS TO CANDIDATES**

1. Do not turn over this page until you are told to do so.
2. Follow all instructions carefully.
3. Answer all questions.

Marks for Booklet B: \_\_\_\_\_ / 44



Booklet B

Write your answers to questions 29 to 40 in the spaces given.  
The number of marks available is shown in the [ ] at the end of each question or part question.

(44 marks)

- 29 Ethan observed plant P as shown in the diagram below.  
He noticed that the fruit was of a bright orange colour and was very juicy.

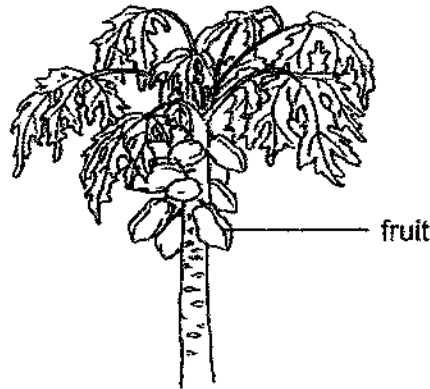

Plant P

- (a) Based on the information given, state how plant P reproduces. [1]

\_\_\_\_\_

- (b) State the method of dispersal of plant P. Explain your answer.

\_\_\_\_\_

\_\_\_\_\_

Please do not write in the margin.

Please do not write in the margin.

**Question 29 continued**

Ethan carried out an experiment with seeds, using the steps listed below.

- He placed the same number of seeds in each container of soil.
- The container in set-up A was placed in a refrigerator at 2°C for three days.
- The container in set-up B was placed on the dining table at 29°C for three days.
- The seeds were given the same amount of water and were watered every day.
- He recorded his observations in a table as shown below.

	Set-up A (at 2°C)	Set-up B (at 29°C)
Day 1		
Day 3		

Please do not write in the margin.

Please do not write in the margin.

(c) Based on the information given, state the aim of Ethan's experiment. [1]

---



---

(d) Based on his observations, what can he conclude from the experiment? [1]

---



---

Question 29 continued

Ethan saw that Plant Z has both male flowers and female flowers, but they grow separately, as shown in the diagram below.

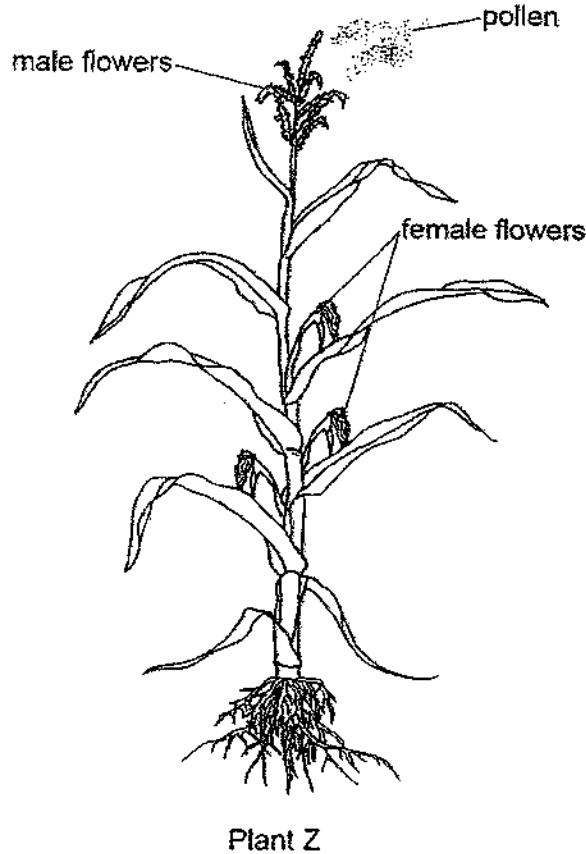

Please do not write in the margin.

Please do not write in the margin.

Plant Z is pollinated by wind.

- (e) Using the information given, explain how the positions of the male and female flowers help plant Z to be pollinated easily. [1]

---

---

- 30 A mountain climber climbed to different heights of a mountain. At each height, he rested and measured his breathing rate.

He also recorded how much oxygen there was in the air at each height. The results are shown in the two graphs below.

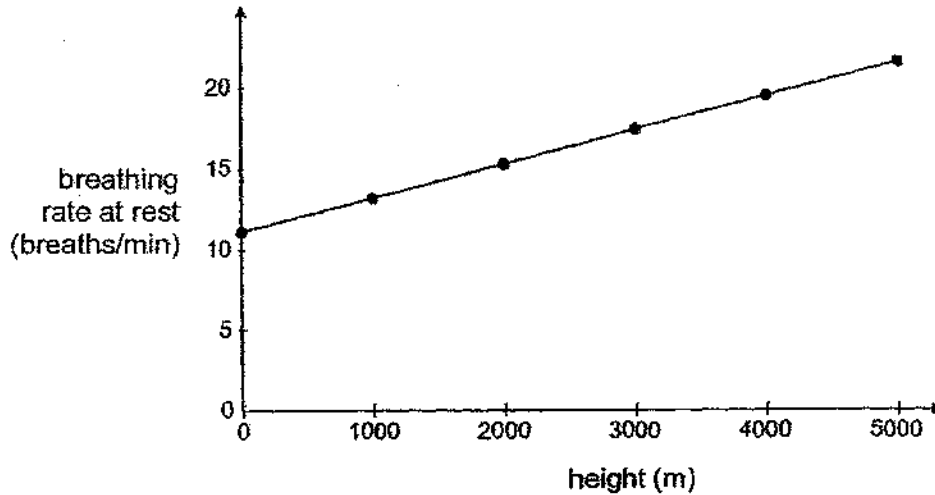
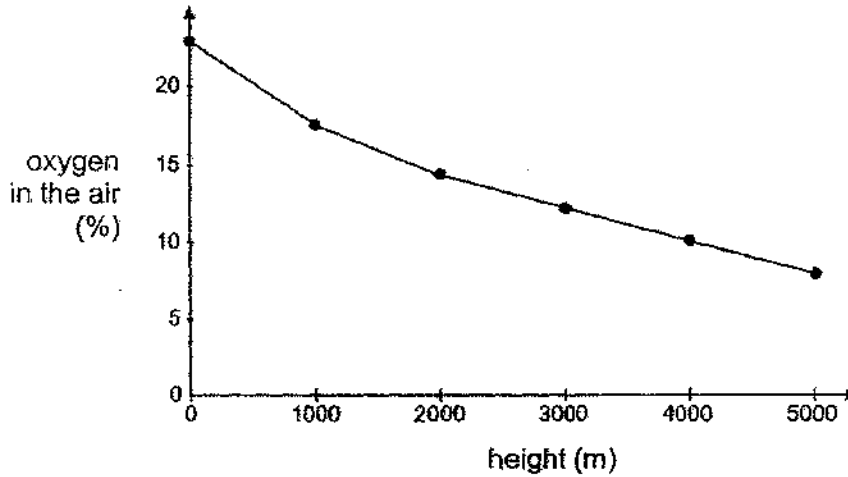

- (a) Based on the graphs above, state the relationship between the percentage of oxygen in the air and his resting breathing rate at different heights. [1]

---



---

- (b) Explain why the relationship stated in (a) is observed. [2]

---



---



---

31 The diagram below shows the movement of water in a plant.

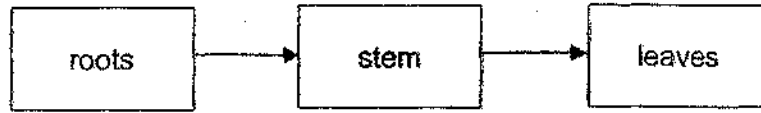

(a) State what happens to the water after it reaches the leaves. [1]

\_\_\_\_\_

The arrows below show the flow of blood in the human body.



(b) State one difference between the direction of movement of water in plants and the direction of movement of blood in the human body. [1]

\_\_\_\_\_  
\_\_\_\_\_  
\_\_\_\_\_

(c) State the function of the heart. [1]

\_\_\_\_\_  
\_\_\_\_\_

Please do not write in the margin.

Please do not write in the margin.

- 32 Rex wanted to find out if the amount of light affects the rate of photosynthesis. He set up an experiment as shown in the diagram below.

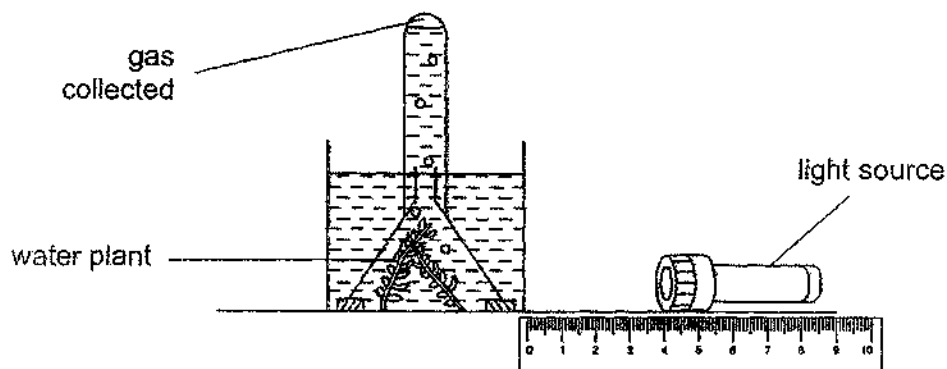

His results are shown below.

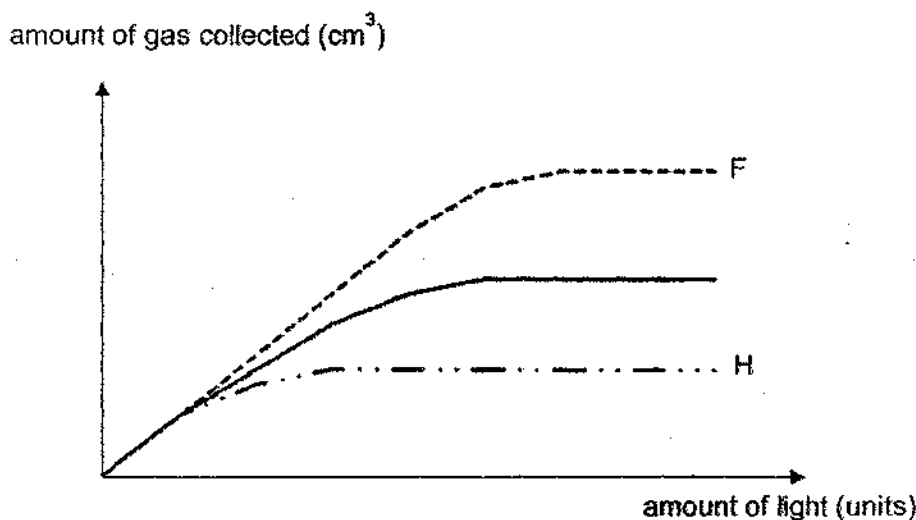

Please do not write in the margin.

Please do not write in the margin.

He then repeated the experiment by moving the light source further away.

- (a) Which graph, F or H, shows his likely results? Explain your answer. [2]

---



---

- (b) Suggest a reason why measuring the amount of gas collected is more accurate than counting the number of bubbles produced.

---



---

- (c) Suggest why the amount of gas collected stops increasing after a certain point, even though the amount of light keeps increasing. [1]

---

33 Some animals that live in hot places lose heat through their ears.

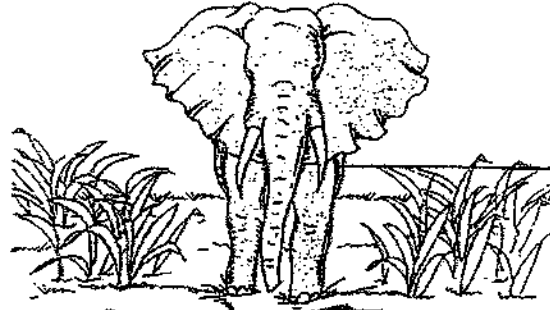

elephant G

Elephant G lives in a hot and open grassy area and has large ears as shown above.

(a) Explain why large ears could be an advantage for elephant G.

[1]

---

---

Elephant H lives in a thick forest and has smaller ears compared to elephant G as shown below.

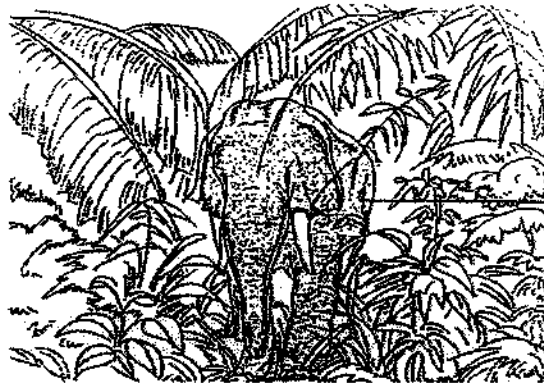

elephant H

(b) Explain why large ears could be a disadvantage for elephant H.

[1]

---

---

Please do not write in the margin.

Please do not write in the margin.

- 34 The diagram below shows two organisms, organism J and organism L living together.  
 Organism J has chlorophyll while organism L is able to absorb water and mineral salts from its surrounding.

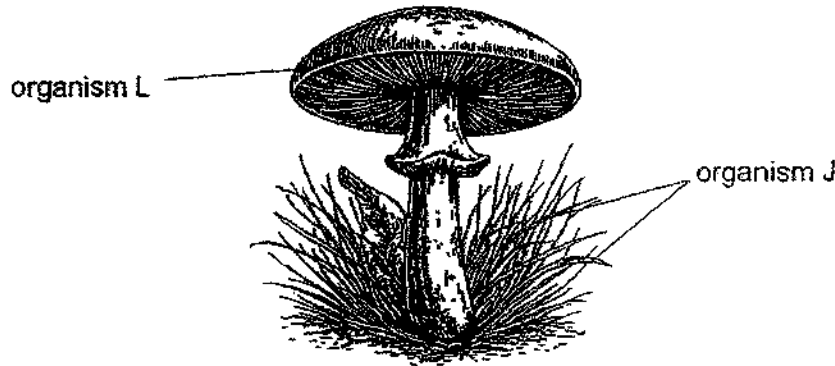

- (a) How does organisms J and L benefit each other? [2]

Benefit for organism J:

---

Benefit for organism L:

---

Please do not write in the margin.

Please do not write in the margin.



Question 34 continued

The graphs below show the number of factories and the population of organism J in city A over a period of five years.

A lot of land area is needed to build more factories throughout the five years.

Number of factories

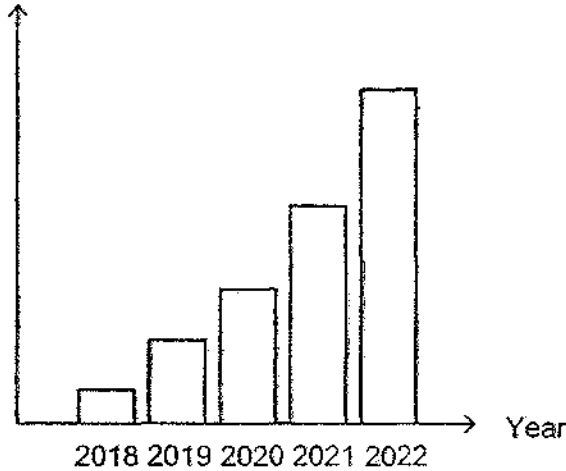

Population of organism J

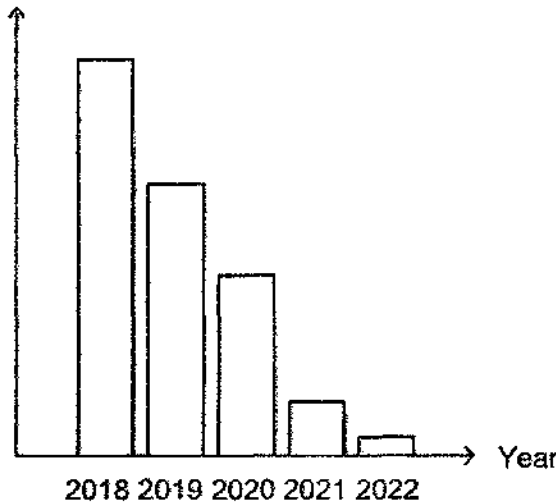

Please do not write in the margin.

Please do not write in the margin.

(b) What will happen to the population of organism L?

[2]

Explain how the increase in the number of factories in city A caused the change in the population of organism L.

---



---

- 35 Junho conducted an experiment to compare the rates of evaporation of water in containers X, Y and Z. He poured the same amount of coloured water into each of the three containers. He placed the three set-ups near a window for a day.

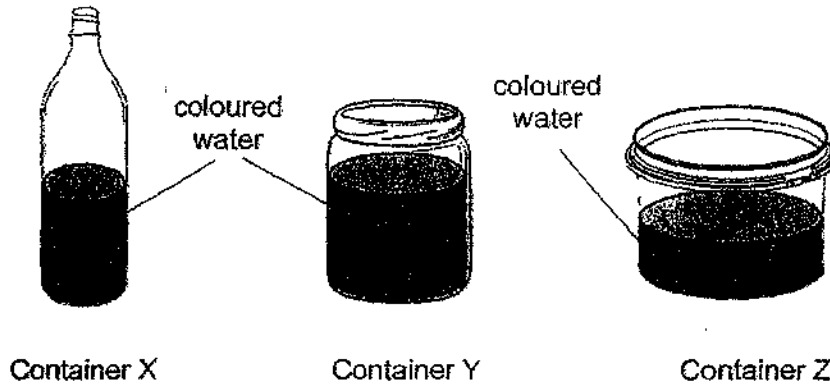

- (a) Based on the results of the experiment, Junho concluded that water in container Z evaporated the fastest.

Explain how Junho arrived at this conclusion.

[2]

---



---



---

The graph below shows the rate of evaporation of water in the day of the experiment.

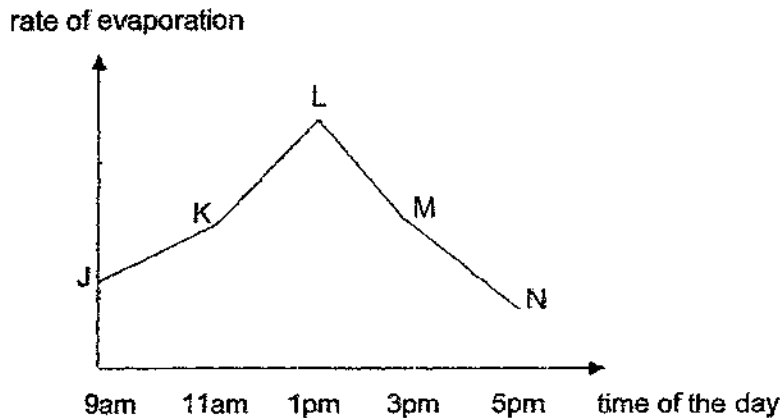

- (b) Which part of the graph above (JK, KL, LM or MN) shows the highest rate of evaporation of water during the day? Explain your answer.

[1]

---

Please do not write in the margin.

Please do not write in the margin.

36 (a) State what temperature is. [1]

---



---

Yan Yan wanted to find out which material was the best conductor of heat. She scooped butter on three similar spoons and placed them in a basin of water at 5°C. The spoons were made of different materials, E, F and G.

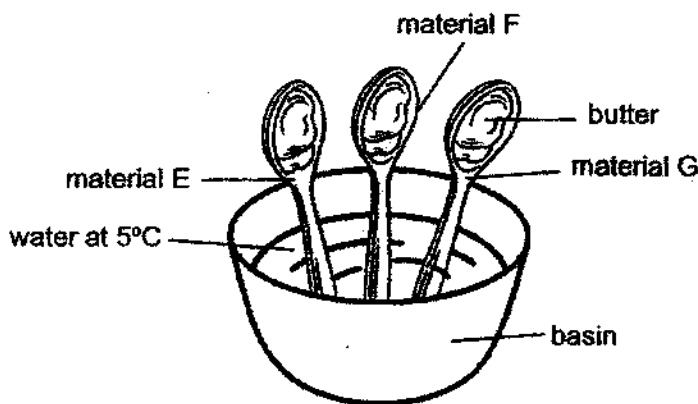

(b) State the variable Yan Yan changed in her experiment. [1]

---

(c) Explain why it is important to ensure that the same amount of butter is scooped on each spoon. [1]

---



---

(d) Suggest one way Yan Yan can make sure that the water in the basin remains cold during the experiment. [1]

---



---

Please do not write in the margin.

Please do not write in the margin.

37 Joe and Ray wanted to investigate on which pair of shoes would be the least slippery and the most suitable to wear on a rainy day.

They had three similar pairs of shoes to compare.

The diagrams below show the soles of the shoes and the number of treads on the sole of each shoe.

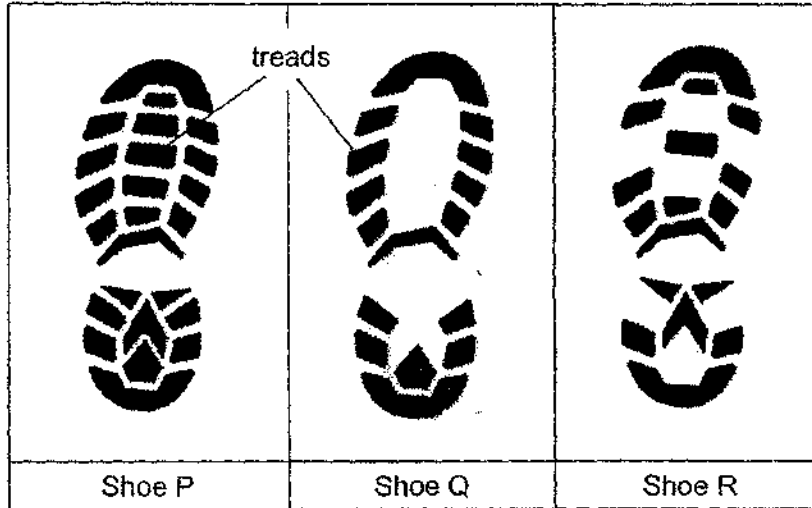

(a) Based on the information given, write a suitable hypothesis for Joe and Ray's investigation. [1]

---



---

For their investigation, the boys measured the time taken for each shoe to slide down a ramp. The diagram shows their experimental set-up.

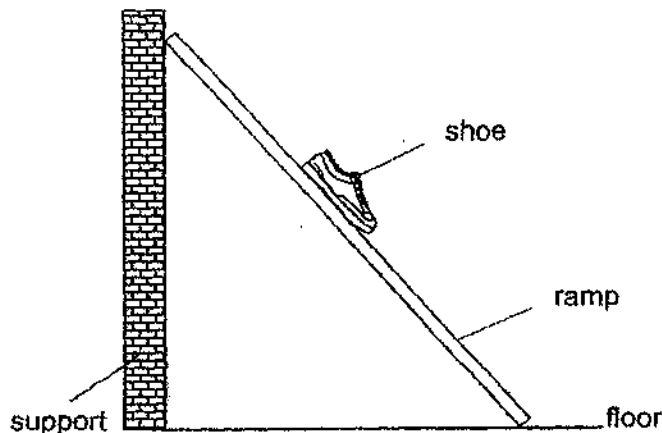

Please do not write in the margin.

Please do not write in the margin.

Question 37 continued

- (b) In each of the diagrams given below, draw an arrow to show the direction of (i) gravitational force and (ii) frictional force acting on the shoe as it slides down the ramp. [2]



direction of gravitational force acting on the shoe

direction of frictional force acting on the shoe

- (c) Suggest a change to the surface of the ramp that would make the shoe slide down more quickly. Explain your answer. [1]

---



---

Please do not write in the margin.

Please do not write in the margin.

38 Sheldon was playing bowling. He bowled a ball along a bowling lane to knock down the pins at the end of the lane as shown below.

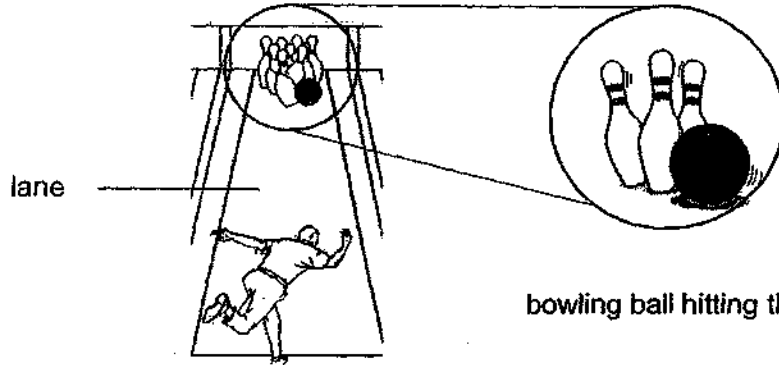

As the ball moved towards the pins, it slowed down.

(a) Explain why the ball slowed down. [1]

---

---

The diagram below shows the ball and one of the pins.

(b) Draw an arrow on the diagram to show the direction of the force on the pin exerted by the ball when it hits the pin. [1]

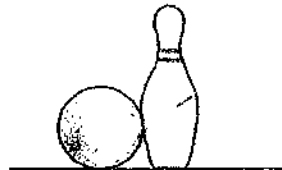

Sheldon tried out bowling balls of different masses. He realised that the bigger the mass of the ball, the more pins he knocked down.

(c) Using energy conversion, explain why he was able to knock down more pins with a ball of larger mass. [1]

---

---

(d) State the energy conversion after Sheldon rolls the ball.

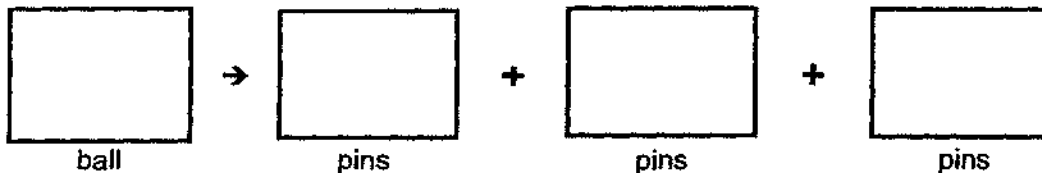

Please do not write in the margin.

Please do not write in the margin.

- 39 Diagram 1 shows the front view of Melissa's toy police car. She sets up an electric circuit in the toy by using bulb M and batteries as shown in diagram 2. All the components in the circuit are working.

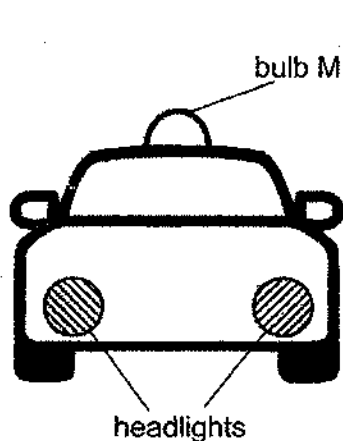

Diagram 1

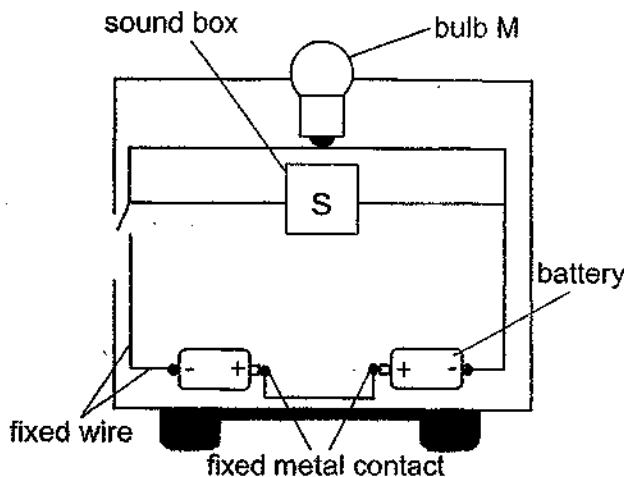
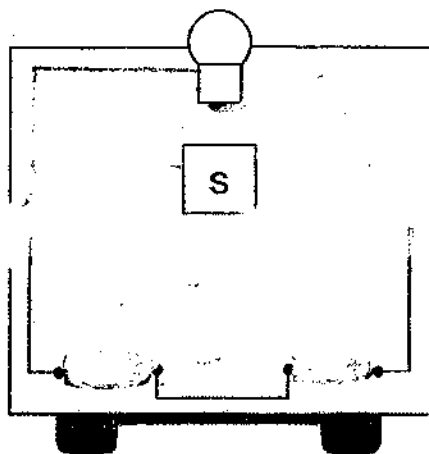

Diagram 2

When she closes the switch, the bulb does not light up and there is no sound.

- (a) Complete the circuit below, correcting the mistake(s).

[2]



Melissa adds two other bulbs for the headlights of the toy. When she closes the switch, all three bulbs will light up without dimming bulb M.

- (b) State how the two bulbs will be connected in the circuit above.

[1]

- 40 W is an iron bar placed inside a coil of wire. P and Q are two iron pins in contact with each other. Pin P is fixed. Pin Q is attached to a metal rod and can move sideways. A spring has been attached to both circuits as shown below.

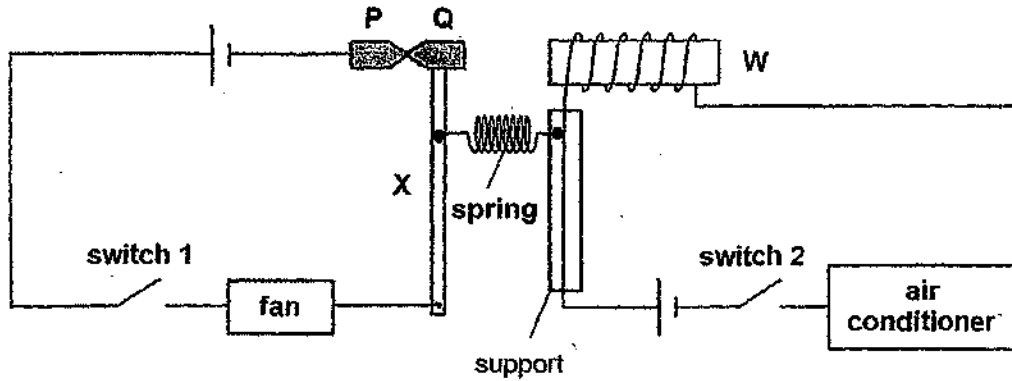

During a hot day, Mani closed switch 1 and the fan was turned on. His sister, Rani, felt that the room was still too warm and closed switch 2 to turn the air-conditioner on.

- (a) What would happen to pin Q when switch 2 was closed? [2]  
Explain your answer.

---



---



---

- (b) What would happen to the fan when Rani closed switch 2? [2]  
Explain your answer.

---



---



---

- (c) Explain how the fan and the air conditioner system Mani had designed could help to conserve energy [1]

---



---

Please do not write in the margin.

Please do not write in the margin.



**SCHOOL : HENRY PARK PRIMARY SCHOOL**  
**LEVEL : PRIMARY 6**  
**SUBJECT : SCIENCE**  
**TERM : PRELIMINARY EXAMINATION**

Booklet A

Q1	Q2	Q3	Q4	Q5	Q6	Q7	Q8	Q9	Q10
1	4	4	2	2	4	2	1	2	3
Q11	Q12	Q13	Q14	Q15	Q16	Q17	Q18	Q19	Q20
3	2	2	3	2	3	2	2	4	3
Q21	Q22	Q23	Q24	Q25	Q26	Q27	Q28		
1	1	2	2	3	2	4	2		

Booklet B

29	<p><b>a</b> Reproduce by seeds.</p> <p><b>b</b> By animal(s). Its fruits are brightly coloured and juicy to attract animals.</p> <p><b>c</b> To find out how temperature affects germination.</p> <p><b>d</b> Seeds germinate in warm conditions / cannot germinate when temperature is too low.</p> <p><b>e</b> When the male flowers release pollen from the top, the wind carries the pollen downwards (or gravity pulls the pollens downwards) making it easier for the female flowers located below to catch the pollens.</p>
30	<p><b>a</b> The lower the amount of oxygen in the air, the higher the resting breathing rate.</p> <p><b>b</b> As he climbs up, there is lesser oxygen in the air, so the climber breathes faster to take in the same / sufficient amount of oxygen.</p>
31	<p><b>a</b> Water is used to carry out photosynthesis.</p> <p><b>b</b> 2 main points (showing comparison)            In plants, water moves only in one direction (from the roots to the leaves).            In the human body, blood moves in two directions (from the heart to the body / lungs and then back to the heart)</p> <p><b>c</b> To pump blood throughout the body</p>
32	<p><b>a</b> H. The intensity of light decreases as the distance between the light source and the water plant increases. Rate of photosynthesis decreases.</p> <p><b>b</b> The amount of gas in each bubble may not be the same.</p> <p><b>c</b> There was not enough carbon dioxide in the water.</p>

33	<p><b>a</b> Having a larger surface area to lose heat (to the surrounding)</p> <p><b>b</b> Thick forest is cooler (and shadier); they may lose more heat with large ears</p>
34	<p><b>a</b> Organism J gets water from the fungi to make food. Organism L takes in the oxygen / sugar produced by the organism J during photosynthesis.</p> <p><b>b</b> The population of organism L decreased. (Evidence) As the number of factories increases, the population of organism J decreases as more land is being cleared so the habitat of organism J / L was destroyed. (Reason) Population of organism L will also decrease as they will not be able to grow and reproduce.</p>
35	<p><b>a</b> key points to arrive at the correct conclusion</p> <ul style="list-style-type: none"> <li>• measured and compared the amount of water left in each container at the end of the experiment</li> <li>• container Z had the least amount of water</li> </ul> <p><b>b</b> KL shows the highest rate of evaporation because the slope of the graph is the steepest between 11am and 1pm, meaning evaporation happens the fastest during this period.</p>
36	<p><b>a</b> It is a measurement of how hot or cold something is.</p> <p><b>b</b> Material of the spoon.</p> <p><b>c</b> To ensure a fair test. To ensure that there is only one changed variable which is the amount of the spoon. To ensure the result is solely due to the changed variable and not any other variables.</p> <p><b>d</b> Add ice to the water in the basin to keep it cold.</p>
37	<p><b>a</b> Shoe P, which has the most treads, will be the least slippery and the most suitable to wear on a rainy day.</p> <p><b>b</b></p> <div style="text-align: center;">  </div> <p><b>c</b> Add lubricants. Adding lubricant would decrease the friction between the shoe and the surface of the ramp, making it slide down more quickly.</p>
38	<p><b>a</b> Kinetic energy and was converted to heat and sound energy as the ball moved towards the pin.</p>

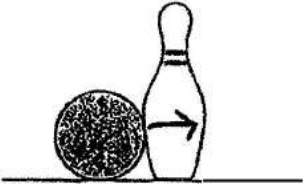
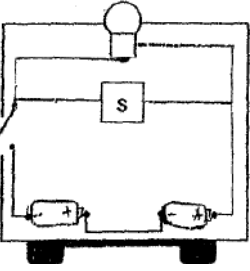
	<p><b>b</b></p>  <p><b>c</b> A ball of larger mass has more potential energy, which is converted to more kinetic energy when it is rolled. This greater kinetic energy allows it to knock down more pins.</p> <p><b>d</b> Kinetic energy → Kinetic energy + Heat energy + Sound energy</p>
39	<p><b>a</b></p>  <p><b>b</b> Parallel</p>
40	<p><b>a</b> When switch 2 was closed, the circuit becomes a closed circuit and electricity could flow through magnetizing W, making W into an electromagnet. The electromagnet would attract pin Q. Pin Q would move to W.</p> <p><b>b</b> The fan would be turned off. When the electromagnet attracts pin Q, it would move to W and the circuit would be an open circuit and electricity cannot pass through, causing the fan to be turned off.</p> <p><b>c</b> So that the fan or the air conditioner could be turned on at once.</p>